

**INTERNATIONAL JOURNAL OF ENGINEERING SCIENCES & RESEARCH
TECHNOLOGY****ASSISTIVE DEVICE FOR DISABLED PEOPLE USING EYE TRACKING****Sudha A.¹, Honey Mol P.K.²**¹Master Student, Department of Electronics and Communication Engineering, of Science and Technology,
Thrissur, India²Assistant Professor, Department of Electronics and Communication Engineering, of Science and Technology,
Thrissur, India

DOI: 10.5281/zenodo.1227197

ABSTRACT

People suffering from different neuromuscular diseases, traumatic injuries in their central or peripheral nervous system often find it difficult to carry out the daily activities such as locomotion and object handling. A powered wheel chair is a mobility-aided device for persons with moderate or severe physical disabilities or chronic diseases as well as for old aged people. The proposed system is an assistive device that combines eye-tracking with a powered-wheelchair mounted hand-exoskeleton, which can assist disabled people in grasping objects while moving around. A control panel based on graphical user interface is designed where the users desire to select command is achieved through eye tracking. The control panel consists of both the wheel chair control panel and hand exoskeleton control panel. Searching of commands on the screen is done by point of gaze and selection is done by eye fixation duration. The eye tracking system consists of camera which captures the movement of eye and it is processed using MATLAB. The eye tracking system provides a signal which mention the command which is chosen by the user. MATLAB communicates with Arduino microcontroller using serial communication. Arduino generates the signal for controlling both wheel chair and hand exoskeleton. The basic functionalities of the system includes navigation such as moving forward, backward, left, right and object handling such as holding and releasing objects.

KEYWORDS: Eye Tracking, MATLAB, Hand Exoskeleton.**I. INTRODUCTION**

In today's world, robots have become an integral part of human life. Robots are becoming more and more pervasive in our everyday lives. Their use spans from high precision industrial manipulators to floor cleaning robots, from space exploration to assistance to first responders. It is envisioned that robots will play a major role in our future society and economy. The developing field of robotic technologies has widespread applications, one of most promising field of which is Robotic Assistive Technologies, where robotic assistive devices can be used to improve the quality of life of people suffering from severe physical disabilities, ameliorating movement and communication and utilizing the latest technologies and innovations to help develop engineering applications and devices to advance mankind.

The ability to move freely is highly valued by all people. However, it is sometimes difficult for a person with a severe motor disability. Though a smart wheelchair is commercially available for disabled people, it generally requires tongue or cheek movement or works on EEG technology which is either irritating and uncomfortable or expensive. Also a few patients lack the ability to control their voluntary muscles needed to control the electric wheelchairs having physical control systems.

People suffering from different neuromuscular diseases, traumatic injuries in their central or peripheral nervous system face several problems in carrying out most common daily life activities such as locomotion and handling household objects. A large number of assistive technologies have been developed to assist these people among which the powered wheelchairs and hand-exoskeletons are the newer trends. Researchers have exploited different modalities to control such devices like kinetic sensors (EEG) and electromyogram (EMG) signals, eye-tracking etc. The absolute point of gaze (POG) can be tracked through several techniques like visual-oculography (VOG), infrared-pupil corneal reflection (PCR) and electro-oculography (EOG). With the advent of

[AIVESC-18]
ICTTM Value: 3.00

low-cost and high precision eye-tracking devices several applications like replacing the mouse in the GUI environment and controlling robotic devices have been implemented successfully. But there is a need to develop robust assistive devices which solves two major purposes of ADL that are locomotion and object grasp. To overcome these shortcomings, this system have explored the possibility of integrating a low-cost eye-tracking device with a powered wheelchair mounted hand-exoskeleton.

LITERATURE REVIEW

The different modalities used to control the devices can be categorized into five i.e Biopotential based methods, Voice based methods, Image Analysis, Motion based methods and search coils. Bio-potential based method which utilizes potential from user's body actions acquired by using special instrument. Instrument such as Electrooculography (EOG), Electromyography (EMG), and Electroencephalograph (EEG), Search coil can be used for measuring bio-potential. The search coil output can be used as sources of computer input for disabled person. EOG method uses voltage differences between fore and aft surface of eyes. But this methods are relatively less accurate and expensive. Voice Based method , uses the voice of the user as an input modality. Voice analysis is used to analyse user's voice and convert into digital data. The weakness of this system is vulnerable against noise. Other voices which come from surrounding user may affect the system. Motion based method, uses the movement of other organs as an input modality. Head, foot, and etc. can be used to control computer input. Uses human effort to navigate like joystick, etc., for a handicapped with any of the organs failed .Several image processing methods are used to analyse user's desire. Search coil method uses induced voltage with coil including in contact lenses attached to user's eyes. Burden to user, here measuring time is limited to approximately 30 to 60 .They have limited Lifetime. Due to the inefficiencies of the existing modalities , eye tracking can be chosen as an better solution.

Eye gaze tracking (EGT) is a kind of technique that can estimate gaze direction of a person. EGT techniques can be classified as intrusive and nonintrusive in light of detection method and system structure. Intrusive techniques require some equipment to be put in physical contact with users such as head mounted devices fixed with optical system so that it is not very convenient. Non-intrusive techniques are mostly vision based, i.e., they use cameras to capture images of face and eyes, using image analysis and processing to get eye feature points, which are then converted to three-dimensional data based on eye imaging model or mapping model, and gaze falling position or direction can be estimated.

Face detection [3] based on the use of eyes tracking system, that can track how long, does the consumer pays attention on current advertising uses the harr-likes features to capture the faces in the image. Then with the similar feature the system can locate eyes on each face, which is called the ROI.

The eye tracker of Tobii [2] can be used to convert eye movement signals into coordinate of gazing points. But these data of gazing points are too diverging to be used directly. Kalman filter algorithm is used to filter data of coordinate and obtain optimal data. By discriminating eye movement-controlled panel area where gazing points is located in, a computer sends appropriate signal to the wheelchair, so as to achieve the goal of moving wheelchair.

Low cost and real time solution [1] to enable differently abled people navigate their wheelchair independently is through movement of eyes. The system accomplished this task by capturing frames of eyeball movement via a webcam which is temporarily mounted on cap. The camera would be mounted on the arm of the wheel chair for ease and comfort. Processing of the eyeball movement is performed on MATLAB environment by employing Voila-Jones algorithm. MATLAB communicates with Arduino micro controller using serial communication.

The purpose of this eye controlled wheelchair is to eliminate the assistance required for the disabled person. In this system controlling of wheelchair [4] is depend on eye movements and central switch. Camera is mounted on wheelchair in front of the person, for capture the image of eye and tracks the position of eye pupil by using some image processing techniques. According to eye pupil position of user, motor will be move in required direction such as left, right and forward

II. MATERIALS AND METHODS

Methodology

The architecture of the system is shown in Figure 1. The proposed system consists of three major components. The first is a human computer interface (HCI) based on eye-tracking. This is composed of a low-cost eye tracking device to capture the point of gaze of the user and translate it into screen coordinates of a visual display unit (VDU) of a laptop, where the combined control panel for the wheelchair navigation and exoskeleton control is displayed..

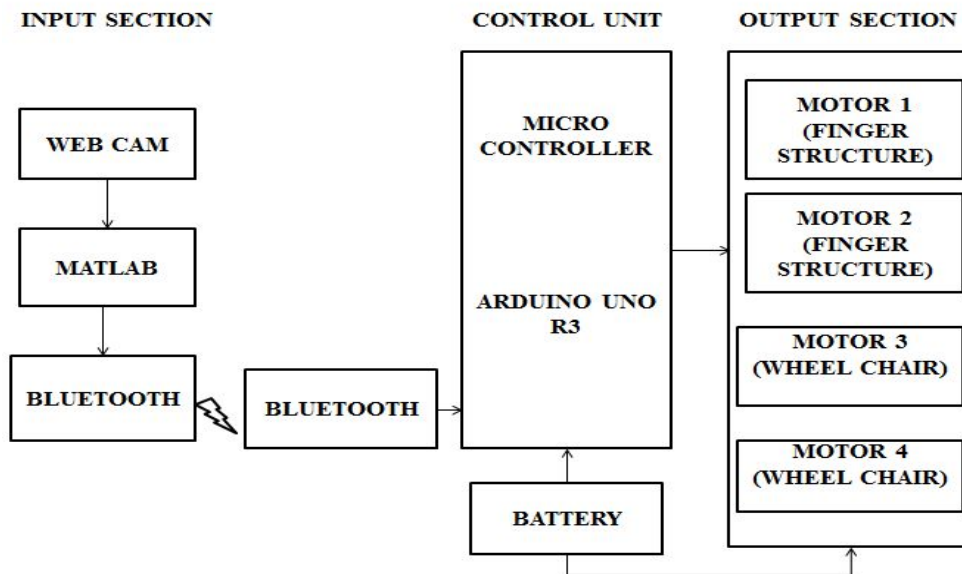

Fig. 1. Block diagram of proposed system

The second is a wheel chair which is used for navigation and the next is the hand exoskeleton which is used for object handling. The basic functionalities of this system are navigations such as moving forward, backward, left, right, forward-left, and forward-right and object handling such as grasping an object, holding it and dropping or releasing it. The GUI includes both wheel chair control panel and hand exoskeleton control panel. An Optical Eye Tracking System is used to capture the image of the eye. It consists of a camera, with which a series of continuous frames of the eye is captured. This images are processed in the Image Processing section, where MATLAB is used for this purpose. Analysis is performed to obtain the correct position of the Iris of the Eye. And then analysing the position in the X-Y plane, the command is chosen. The output signal from the MATLAB which specifies the command, is fed to the controller via Bluetooth. It in turn runs the motors of the wheelchair and hand exoskeleton accordingly.

III. RESULTS AND DISCUSSION

Wheel chair and hand exoskeleton can be controlled by the movement of eye which is tracked using matlab. The result obtained while changing the eye movement left right and straight is shown in the figure. Similarly up and down can be done and used to control the wheel chair motion and hand exoskeleton working.

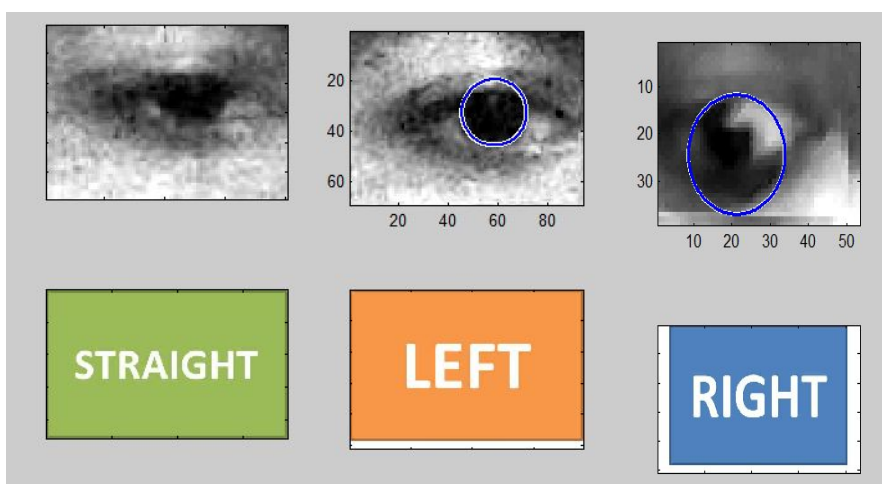

Fig. 2. Direction of eye movement

IV. CONCLUSION

This proposed system contributes to the self-dependency of physically challenged and older people. This paper describes how an eye-tracker based robotic platform can be implemented for controlling a powered wheelchair mounted hand-exoskeleton to cater to the activities of daily living of people suffering from a severe disability of lower and upper-extremities. Unlike the wheelchair mounted robotic arms, this device has the potential to increase the user's motivation as it will feel like they are using their own arm for doing ADLs. The POG being the input modality is useful, as the oculomotor system often remains functioning normally for people suffering from neuro-muscular disabilities

V. ACKNOWLEDGEMENTS

We would like to show our gratitude towards Dr. Sudha Balagopalan, Principal, Vidya Academy of Science and Technology for giving us sole co-operation and encouragement. We thank Dr. S. Swapna Kumar, HOD for assistance and Sruthi. M, Co-ordinator for the comments that greatly improved the manuscript. We thank our colleagues who provide insight and expertise that greatly assisted the project work.

VI. REFERENCES

- [1] Prateek Arora, Anmol Singh Soni, Anshul Sharma, Aman Garg, "Control of Wheel Chair Dummy for Differently Aabled Patients via Iris Movement Using Image Processing in MATLAB" in India Conference, Annual IEEE 2015.
- [2] Dianchun Bai, Zhicheng Liu, Qing Hu, Junyou Yang, Guang Yang, Changlin Ni, Deguo Yang and Long Zhou, "Design of an Eye Movement-Controlled Wheelchair Using Kalman Filter Algorithm", Proceedings of the IEEE International Conference on Information and Automation Ningbo, China, 1664-1668 August 2016.
- [3] Muhammad Affan Zia, Umer Ansari, Mohsin Jamil, Omer Gillani, Yasar Ayaz "Face and Eye Detection in Images using Skin Color Segmentation and Circular Hough Transform", International Conference on Robotics and Emerging Allied Technologies in Engineering Islamabad, Pakistan, April 22-24, 2014.
- [4] Dulari Sahu, "Automatic Camera Based Eye Controlled Wheelchair System Using Raspberry Pi", International Journal of Science, Engineering and Technology Research, Volume 5, Issue 1, January 2016.
- [5] Kaira Matsuzawa, Chiharu Ishii, "Control of Electric Wheel Chair with a Brain Computer Interface Headset" International Conference on Advanced Mechatronic Systems 2016.

CITE AN ARTICLE

It will get done by IJESRT Team